



**INSTALLATION DATA MANUAL
MODEL 544
PRESSURE TRANSMITTER**

**3829 Forest Parkway, Suite 500
Wheatfield, NY 14120
Int'l: 1-716-629-3800
Toll Free: 1-800-688-0030
Fax: 1-716-693-9162
www.viatran.com
solutions@viatran.com**

PRODUCT OVERVIEW

All information contained in this document is representative of a **standard** Model 544. If the product you ordered has special requirements or modifications, refer to the Laser Marked information on the product and your purchase order for possible alteration to the product's configuration. Failure to verify product configuration before installation may cause permanent product damage and in most cases, void the manufacturer's product warranty. If you are unsure or have questions about your product, please contact our Application Engineers for assistance.

Remove and retain all instruction manuals and performance certificates that are shipped with the product. These documents provide important information on the product's calibration, operation, safety precautions, recommended maintenance, re-calibration requirements, repair service instructions and warranty information. These documents are updated from time to time as changes to the product occur and should be reviewed at receipt so that proper and safe installation can occur.

INSTALLATION REQUIREMENTS AND CAUTIONS

1. All electrical and pressure connections should be compatible with the above specifications.
2. The Model 544 is susceptible to sensor damage by being dropped, struck, or installed in a high vibration environment.
3. Due to the effects of gravity on oil fill of the sensor, it is recommended that the product be mounted as shown above. If the product is mounted on its side the effect of gravity will show as a zero offset or product instability.
4. Process media and cleaning solutions should be compatible with 316 SS.
5. Installation should occur only after electrical (input power) and line pressure is verified as being off and at zero.
6. The product's internal electrical circuitry is isolated from case ground. It is not recommended that the case or ground of the unit be connected to the input or output of the product or wiring system. Ground loops and line noise will affect the product's performance and may cause internal electrical failure.
7. All products should be protected from direct or continued exposure to fluids at the electrical connection. The electrical connections on the Model 544 have been designed to be terminated in a junction box or encased in conduit. In applications where moisture or fluid contamination is possible, the use of a NEMA rated connection box is recommended for connection termination.
8. At no time should an object be inserted into the pressure port or pressed against the sensing area to deflect the sensor (to test or simulate pressure) as permanent fill loss and/or damage to the sensing diaphragm may occur.
9. During installation it is recommended that the unit be mounted to allow fluids or contamination to flow away from the module adjustment area, so as not to collect on the screw heads or sockets. (Do not mount the unit facing up.)
10. When installing the unit to a pressure or electrical connection, only use the wrench flats closest to the end being installed. If the unit is being installed on a pressure pipe, only use the 1 1/4" wrench flats at the end where the pressure port is located, not the 1 1/8" flats at the electrical end.
11. When shipped in quantities, units should be packaged individually to eliminate possible damage.
12. To preserve the integrity of the hermetic design, the units have no field replaceable or repairable parts.

INSTALLATION DATA - VIATRAN MODEL 544

Note: The drawing below is for informational purposes only and is not to scale.
All dimensions are nominal, in inches and for reference purposes only.

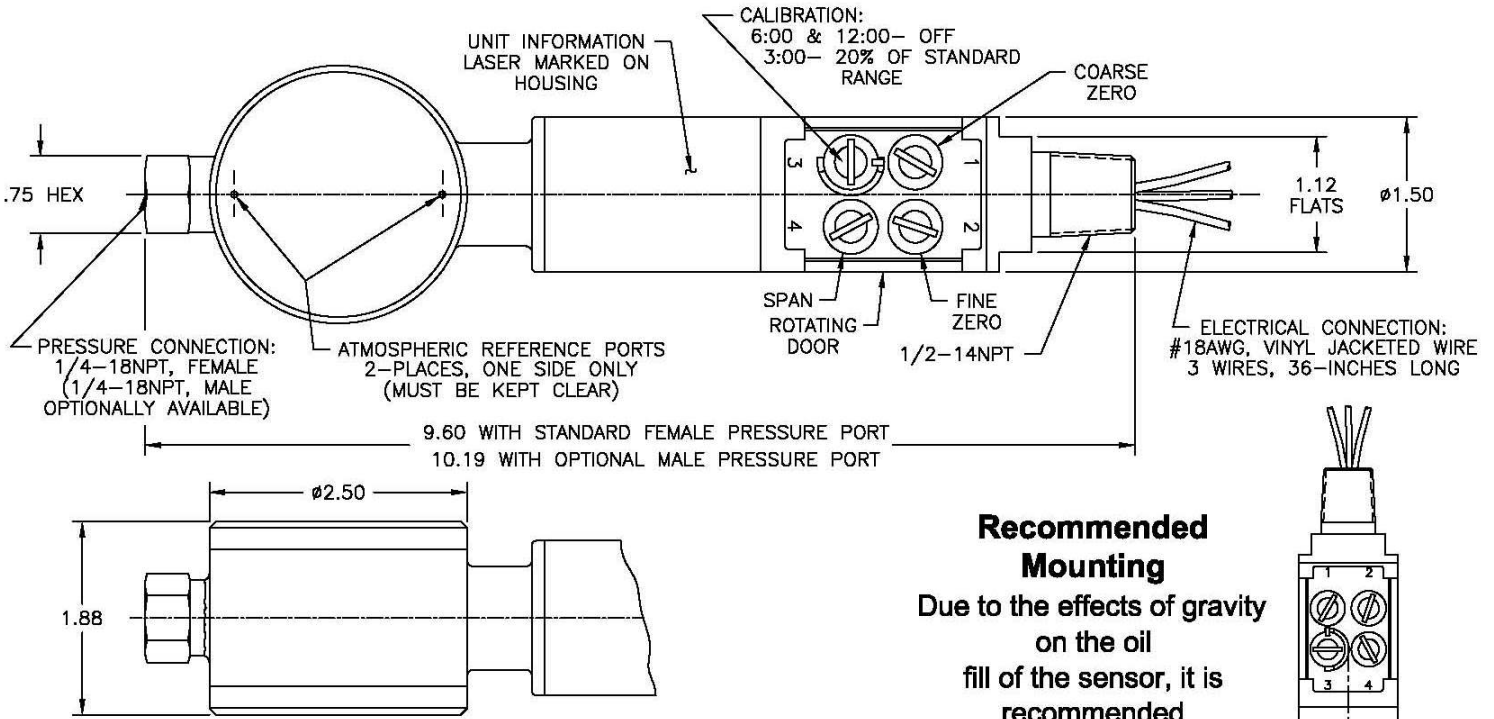

Recommended Mounting
Due to the effects of gravity on the oil fill of the sensor, it is recommended that the product be mounting as shown

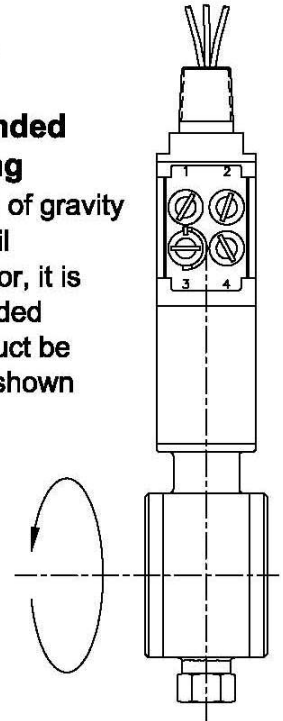

CONNECTION DIAGRAMS & WIRING

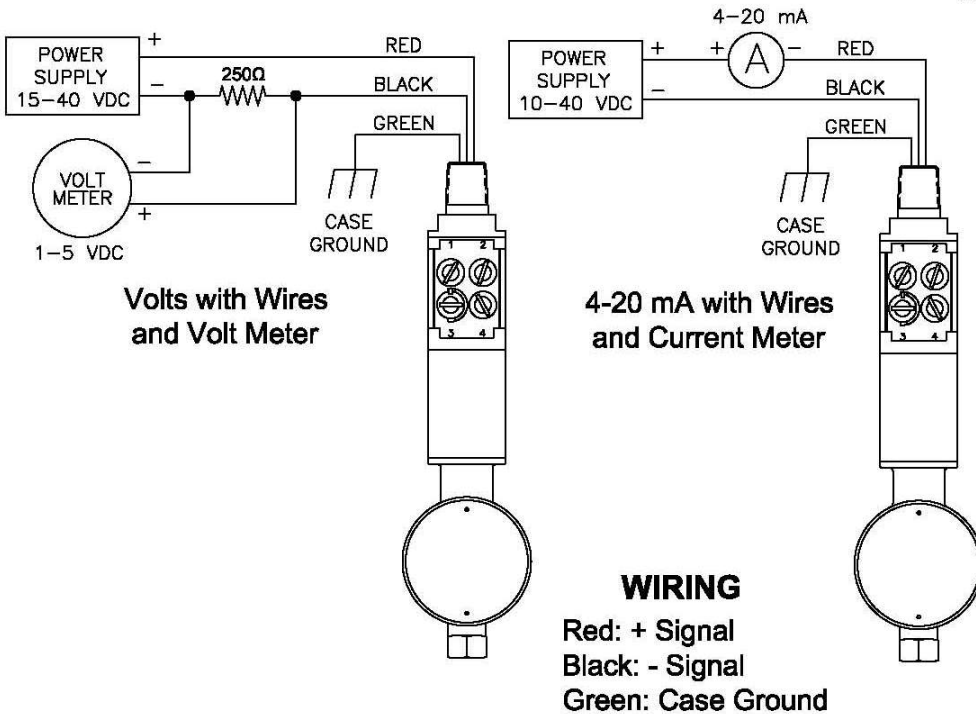

MODEL 544
Output: 4 to 20 mA
Sensor Construction: Oil Filled - Capacitance Cell
Wetted Parts: 316 SST
Pressure Connection: 1/4" NPT female
Electrical Mating Connection: Acceptable 18AWG wire termination connection 1/2" NPT (M)

Note: If the unit is certified for hazardous locations as Intrinsically Safe, use the enclosed connection diagram.

BASIC OPERATION & INTERNAL CALIBRATION CIRCUIT

(See Maintenance and Repair for calibration frequency recommendations.)

Note: The casting of the module has raised numbers at the adjustment screw positions. Those numbers reflect the following function of the assigned screw.
Screw 1: Top Left, Coarse Zero Pot (CCW - Lower, CW - Raise)
Screw 2: Top Right, Fine Zero Pot (CCW - Lower, CW - Raise)
Screw 3: Lower Left, Internal Cal. Activation Pot (12 or 6 o'clock position – Disengage; 3 o'clock position - Engage)
Screw 4: Lower Right, Span Adjustment Pot (CCW - Lower, CW - Raise)

1. Outside of using the calibration circuit or the availability of a metrology lab for obtaining a pressure (Full Scale) reading, no object should be used to physically move the sensor.
2. Once proper connections and power are applied, the unit should begin to function.
3. Check the zero output (4.00 mA) with the performance certificate to verify readings. If it is out of specification from the performance certificate, use the coarse and fine zero adjustment screws to obtain the proper reading.
4. With no pressure applied, engage the calibration circuit by slowly rotating the calibration screw until the current output rises to about 8.80 mA's. Check the reading with the performance certificate. If the reading is off, adjust the span screw to raise or lower the reading – return the calibration circuit to the original position.
5. When making zero and/or span adjustments, there may be some interaction between the zero and span readings - repeat adjustments if needed.
6. Always return the calibration screw to off or full CCW position before installing the transmitter into the application. Note: This is a common reason for incorrect readings at start-up. The calibration circuit must be deactivated in order for the product to perform properly.
7. Once the product has been tested and functionality verified, the power and meter connections may be removed and the product reconnected to the instrumentation loop.

NON-STANDARD RANGE (NSR) CALIBRATION

NSR: A non-standard range is an alternate scaled reading as requested by the customer. Through the use of a single transmitter, numerous pressure ranges can be set-up. The Model 544 can be scaled down to any pressure range, from five times the original range. Only NSR requests for ranges less than the sensor rated range are recommended and in most cases possible. The NSR is possible due to the ability of the adjustment screws to alter where the zero and span will fall. Refer to the below example for field NSR calibration.

NSR EXAMPLE

You have Viatran's Model 544 with a standard range of 0 to 100 PSI. You would like to set an NSR of 0 to 50 PSI. Refer to the Performance Certificate and obtain the following:

Zero = 0 PSI = 4.00 mA

Full Scale = 100 PSI = 20.00 mA

Cal Value = 20.04 PSI = 8.81 mA

In order to recalibrate the transmitter, you must determine the cal reading in mA's at the NSR range. This is done by calculating what the cal output should be at the NSR range. For the example listed, the standard calibration value is set to represent 20.04 PSI. Once internally set, the calibration (Cal) will always represent this pressure.

Use the formula: $\text{Cal mA's} = [(16 \times \text{Standard Cal Pressure}) / \text{desired range}] + 4$

Substitute Actual Numbers: $\text{Cal mA's} = [(16 \times 20.04) / 50] + 4$

$\text{Cal mA's} = (320.64 / 50) + 4$

$\text{Cal mA's} = 6.413 + 4$ Cal mA's = 10.413 mA's

The zero would be set for 4.00 mA's, and the calibration circuit will read (after adjusting span) 10.413 mA's when activated. This would provide a new NSR range for the unit of 4-20 mA's over 0-50 PSI.

ACCESSORIES - OPTIONAL EQUIPMENT

Polypropylene Conduit Connection Box - NEMA 4X (4 Connection, Dual Terminal Block)	10000PT-25
Polypropylene Conduit Connection Box (10000PT-25) with 8 Ft. Cable.....	003667.003
Polypropylene Mounting Bracket (Surface Mount)	004102.013 Stainless
Steel Mounting Bracket (Surface Mount)	004016.002 Mounting
Bracket (2" Pipe Mount)	003633.002 Digital
Indicator (Panel Mount)	Consult Factory
Direct Mount Indicator	Consult Factory

PREVENTATIVE MAINTENANCE

Note: This checklist should be followed each time a transmitter requires preventative maintenance. Depending on product usage cycle, all maintenance should be done on a schedule that is reflective of the application.

1. The sensor surface should be visually checked whenever the unit is removed or every 6 months (usage dependent). Any visible damage, especially deep gouges, pits, or cuts in the sensor, would require the unit to be returned to Viatran for evaluation.
2. Care should be used when handling the unit by the connection wires. Continued movement of these wires will weaken the seal. Seal failure will result in internal contamination and non-warranty product failure. Visually inspect the connection area every 6 months (usage dependent).
3. The module door should always remain closed over the adjustment screws. Constant exposure of the adjustment screws to mists, dusts or contaminants could cause them to become "frozen" in place, causing the module to become locked and non-usable. This would render external adjustment difficult at best. Replacement magnets are available if this problem occurs. Hence a visual inspection of the calibration pots should take place on a 2 to 4 week schedule, or when extreme environmental conditions require it.
4. **NEVER** - Strike a presumed failed transmitter. If the transmitter is in working order, the shock could cause additional failure.
NEVER - Remove a transmitter from an instrumentation loop with the power on. Protection circuitry designed to absorb small power surges could become shorted and cause transmitter failure due to "arcing".
NEVER - Ground a transmitter to AC Return (Black). Instant "fatal" failure occurs.
NEVER - Apply input power to the case ground (Green wire). Reduced life span of protection components will occur.

MAINTENANCE AND REPAIR

All Viatran transmitters have been designed to function free from routine or scheduled maintenance. Simple cleaning of the electrical connector, pressure port threads and pressure cavity on an as needed basis will provide many years of satisfactory performance. Protecting the product from continued exposure to moisture or fluids at the electrical connection, breather area (model dependent) will eliminate premature internal failure of the product. Generally any time the product is removed from service the connector and pressure port threads should be cleaned and the pressure cavity flushed with a 316 stainless steel compatible cleaner to prevent media buildup.

It is suggested that the calibration be verified on a usage dependent schedule. If the product is in continuous service 7 days a week, then calibration verification may be necessary every 6 to 8 months. If the product is in a lab test environment a more lenient verification schedule would be appropriate. In all instances the performance of the product will depend on the individual application or process in which it is installed. More continued usage would require a shorter period between calibration verification and product maintenance.

If a product is perceived to be exhibiting problems, it can be returned to Viatran for analysis and/or repair. It is suggested that only Viatran personnel attempt repair of the product. Any damage resulting from customer disassembly would result in a loss of coverage under the warranty policy. All Viatran products are able to be repaired at minimal cost if simple cleaning and precautions are taken in the handling and application of the product. Older products returned for repair are updated to current specifications unless the repair cost would outweigh the cost of a new replacement model. Products returned for repair should include information on the person to contact for repair quote approval, the individual to contact if Viatran's technical staff requires additional information during analysis, and a brief description of the problem associated with the product's failure.

WARRANTY

Viatran Corporation warrants that its products shall be free from defective workmanship and/or material for a period of twelve (12) months from the date of shipment, provided that Viatran's obligation hereunder shall be limited to correcting any defective workmanship and/or replacing any defective material f.o.b. factory. No allowance will be made for any expense incurred for correcting any defective workmanship and/or material without written consent by Viatran. This warranty is in lieu of all other warranties expressed or implied.

REPAIR INSTRUCTIONS

Viatran's Transmitters are designed to be easily repaired and recalibrated if necessary. If a failure occurs, the transmitter should be returned to the factory for inspection and testing. Please contact the Customer Support Department at 1-800-688-0030, for a return tracking number and/or a repair cost estimate. A nominal inspection fee is charged on all units returned to the factory which are not subsequently repaired.